

***PARTI DI RICAMBIO***  
***SPARE PARTS***

**ITALIANO**  
**PARTI**  
**DI RICAMBIO**

**ENGLISH**  
**SPARE**  
**PARTS**



In ogni pagina del capitolo “Parti di ricambio” sono individuate le parti principali d’ogni gruppo della macchina. Tali parti sono indicate univocamente da un numero progressivo. Nella tabella sottostante le fotografie, sono indicati tali numeri, i codici e una breve descrizione delle parti corrispondenti ai numeri menzionati nelle fotografie. Al momento dell’ordine di una qualsiasi parte di ricambio **dovranno essere inviati alla OMGA S.p.A. i seguenti dati:**

1. Codice della macchina (in copertina sotto il logo OMGA).
2. Modello della macchina.
3. Codice della/e parte/i di ricambio.
4. Quantità.

Non saranno accettati ordini senza i dati sopracitati.

Each page of the “Spare parts” section illustrates one of the main units of the machine. Each part of a unit is identified by a progressive number. The table under the photograph contains these numbers, the relevant identification codes and a short description of the part. When ordering spare parts from OMGA S.p.A., **always quote the following information:**

1. Machine code number (on the cover under the OMGA logo).
2. Machine model.
3. Code(s) of the spare part(s).
4. Quantity

**Orders not including the above information will not be accepted.**

**ITALIANO**  
**PARTI**  
**DI RICAMBIO**

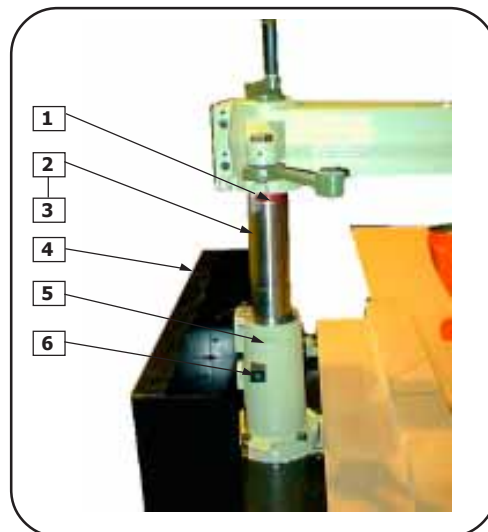

**ENGLISH**  
**SPARE**  
**PARTS**

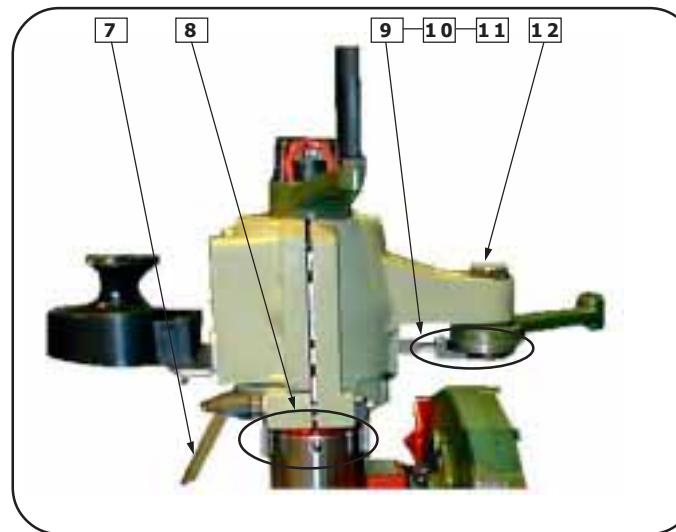

**ITALIANO**

**ENGLISH**

<b>N°</b>	<b>CODE</b>	<b>DESCRIZIONE</b>	<b>DESCRIPTION</b>
1	375	SETTORE GRADUATO	SCALED SECTOR
2	131	COLONNA	COLUMN
3	132	VITE SOLLEVAMENTO	LIFTING SCREW
4	60975	CAPPA ASPIRAZIONE	DUST EXTRACTION HOOD
5	123	SUPPORTO COLONNA	COLUMN SUPPORT
6	1400301000	PARACOLPO	BUFFER
7	1401001800	LEVA A SCATTO	SPRING LEVER
8	60981	PERNO ANTIROTAZIONE BRACCIO	ARM ROTATION LOCKING PIN
9	158	PERNO BLOCCAGGIO BRACCIO	ARM LOCKING PIN
10	157	BOCCOLA BRACCIO	ARM BUSHING
11	1101101800	VITE	SCREW
12	169	POSIZIONAMENTO LEVA	LEVER POSITIONING PIN

<b>ITALIANO</b>	<b>ENGLISH</b>
<b>PARTI DI RICAMBIO</b>	<b>SPARE PARTS</b>

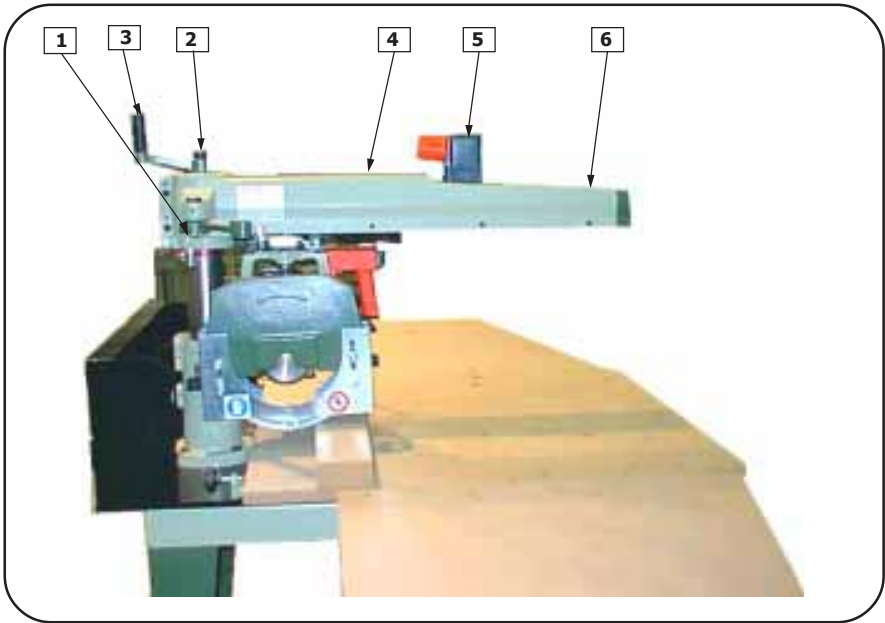

		<b>ITALIANO</b>	<b>ENGLISH</b>
<b>N°</b>	<b>CODE</b>	<b>DESCRIZIONE</b>	<b>DESCRIPTION</b>
1	2425	LEVA SBLOCCAGGIO ROTAZIONE BRACCIO	ARM RELEASE LEVER
2	2094	LEVA SOLLEVAMENTO	LIFTING LEVER
3	080802400	IMPUGNATURA	HANDGRIP
4	2373	BRACCIO PORTANTE	SUPPORT ARM
5	0517925001	GRUPPO FRENO TELESALVAMOTORE	BRAKE UNIT AND REMOTE OVERLOAD CUT OUT
6	126	TESTATA ANTERIORE	HEIGHT HEAD

**ITALIANO**  
**PARTI**  
**DI RICAMBIO**

**ENGLISH**  
**SPARE**  
**PARTS**

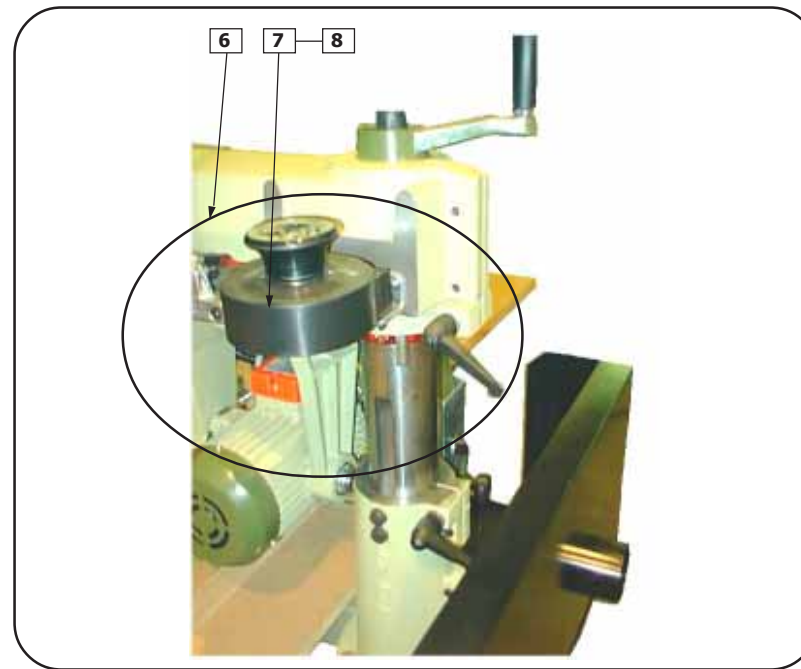
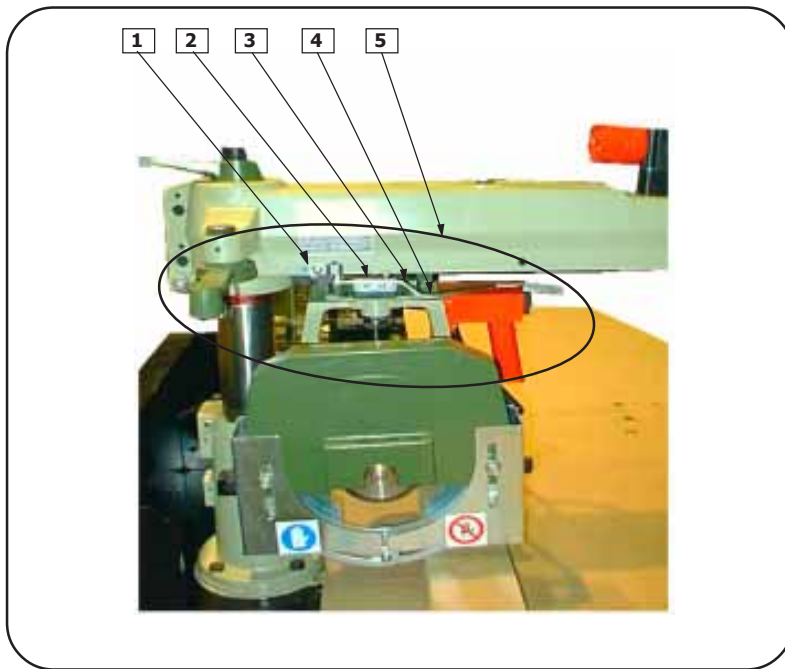

**ITALIANO**

**ENGLISH**

N°	CODE	DESCRIZIONE	DESCRIPTION
1	9599	AGGANCI	HOOK
2	9600	MOLLA	SPRING
3	9597	SUPPORTO LEVA SBLOCCAGGIO	RELEASE LEVER MOUNT
4	9598	LEVA SBLOCCAGGIO	RELEASE LEVER
5	720450530000	BLOCCAGGIO GRUPPO	UNIT LOCK
6	720020530000	GRUPPO RITORNO AUTOMATICO	AUTOMATIC REVERSAL UNIT
7	660040010000	BILANCIATORE	BALANCING DEVICE
8	61034	SUPPORTO BILANCIATORE	BALANCING DEVICE SUPPORT

<b>ITALIANO</b> <b>PARTI</b> <b>DI RICAMBIO</b>	<b>ENGLISH</b> <b>SPARE</b> <b>PARTS</b>
---	--

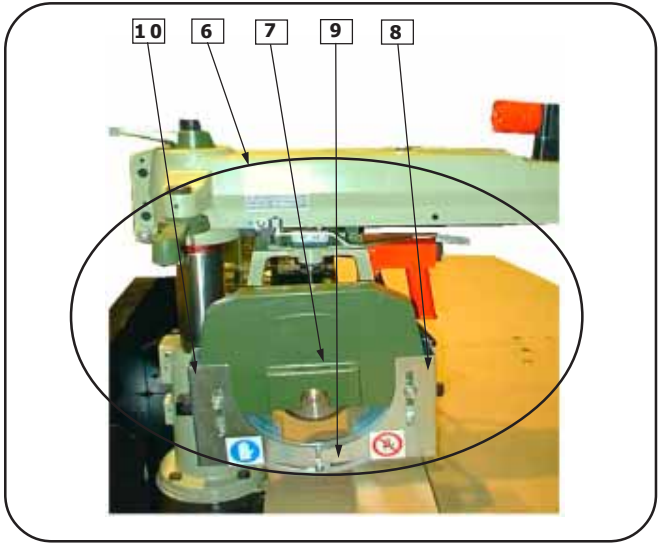

		<b>ITALIANO</b>	<b>ENGLISH</b>
<b>N°</b>	<b>CODE</b>	<b>DESCRIZIONE</b>	<b>DESCRIPTION</b>
1	080010300	Volantino	Handwheel
2	1701102609	Cilindro semplice effetto	Single effect cylinder
3	1038	Squadro pressore	Presser square
4	080010300	Volantino	Handwheel
5	1764	Pressore	Presser
6	710100080100	CARTER PROTEZIONE LAMA ø 300	DIAM. 300 BLADE GUARD
7	60980	CARTER CIRCOLARE	ROUND CASING
8	60543	PROTEZIONI LAMA ANTERIORE	FRONT BLADE GUARD
9	60544	PROTEZIONI LAMA POSTERIORE	REAR BLADE GUARD
10	2488	PROTEZIONE LATERALE	LATERAL GUARD

**ITALIANO**  
**PARTI**  
**DI RICAMBIO**

**ENGLISH**  
**SPARE**  
**PARTS**

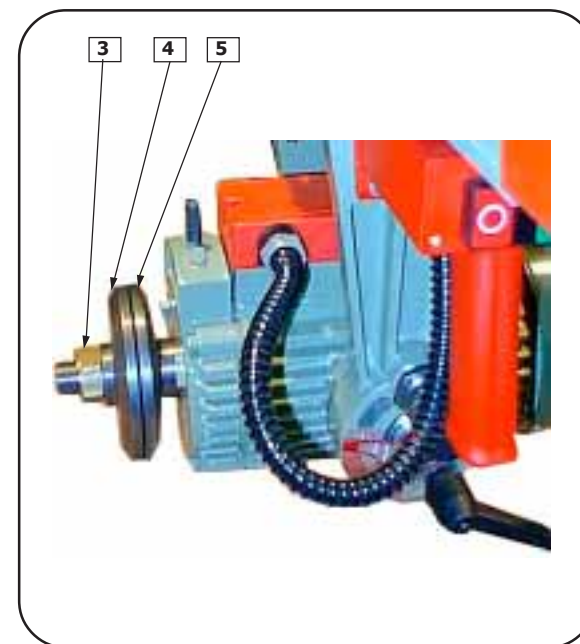
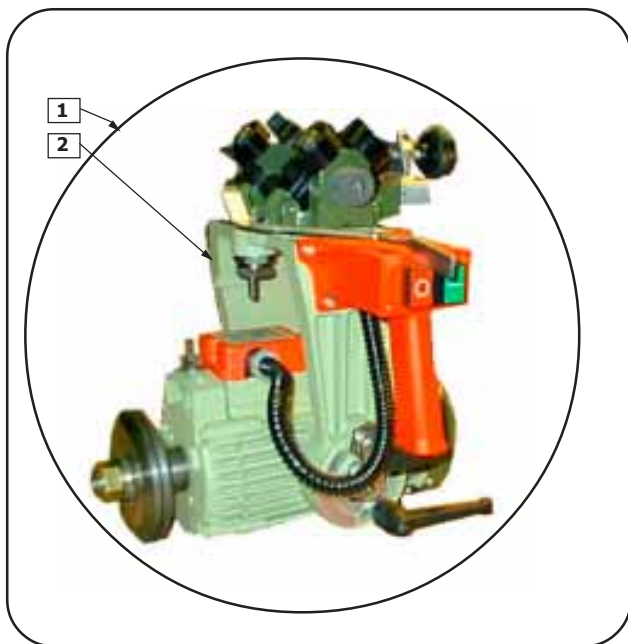

		<b>ITALIANO</b>	<b>ENGLISH</b>
<b>N°</b>	<b>CODE</b>	<b>DESCRIZIONE</b>	<b>DESCRIPTION</b>
1	631090012500	GRUPPO OPERANTE	CUTTING UNIT
2	18161	FORCELLA	FORK
3	1155	DADO CIRCOLARE	CIRCULAR NUT
4	1499	FLANGIA SX	LH FLANGE
5	2003	FLANGIA DX	RH FLANGE

**ITALIANO**  
**PARTI**  
**DI RICAMBIO**

**ENGLISH**  
**SPARE**  
**PARTS**

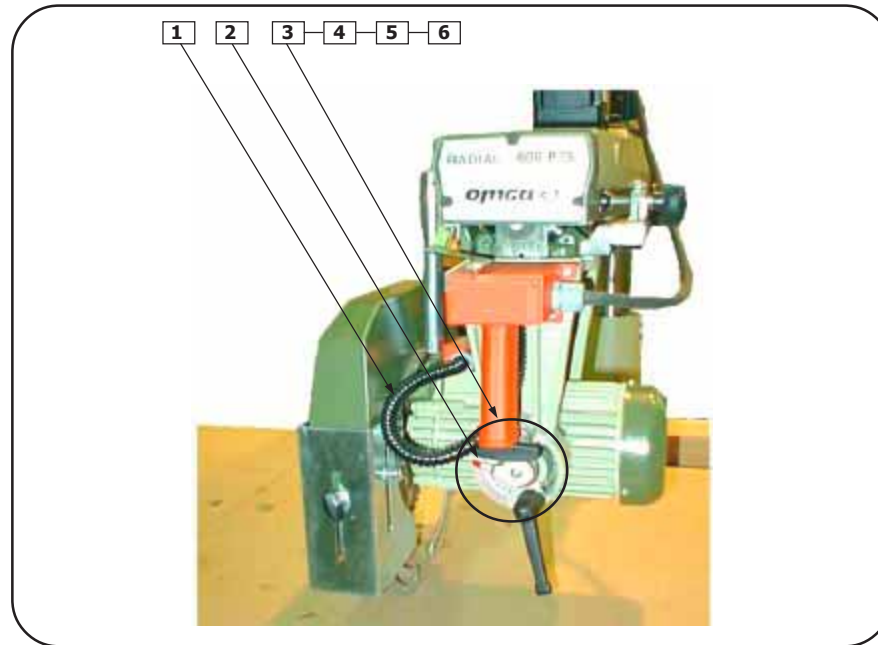

**ITALIANO**

**ENGLISH**

<b>N°</b>	<b>CODE</b>	<b>DESCRIZIONE</b>	<b>DESCRIPTION</b>
1	6763002200	GUAINA IN PVC A SPIRALE	SPIRAL PVC SHEATH
2	0801200700	LEVETTA	LEVER
3	1101308702	BOCCOLA	BUSH
4	160	PERNO	PIN
5	5069	DADO	NUT
6	628	MOLLA	SPRING

**ITALIANO**  
**PARTI**  
**DI RICAMBIO**

**ENGLISH**  
**SPARE**  
**PARTS**

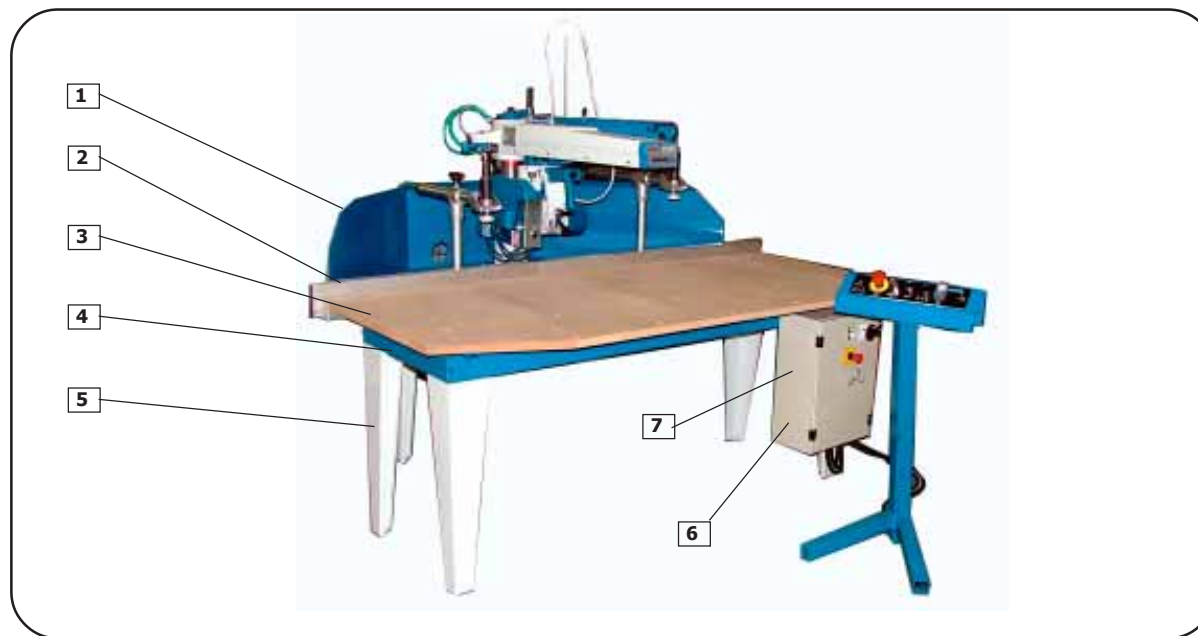

**ITALIANO**

**ENGLISH**

<b>N°</b>	<b>CODE</b>	<b>DESCRIZIONE</b>	<b>DESCRIPTION</b>
1	63197	Cappa di aspirazione	Extractor hood
2	62876	Sponda dx	Right side
3	62877	Sponda sx	Left side
4	62874	Tavolo	Workbench
5	62875	Banco	Bench
6	516	Piede	Foot
7	0517347301	Impianto elettrico	Electrical system
8	0518621625	Scheda per frenatura motore	Motor braking card

<i>ITALIANO</i>	<i>ENGLISH</i>
<i>PARTI DI RICAMBIO</i>	<i>SPARE PARTS</i>

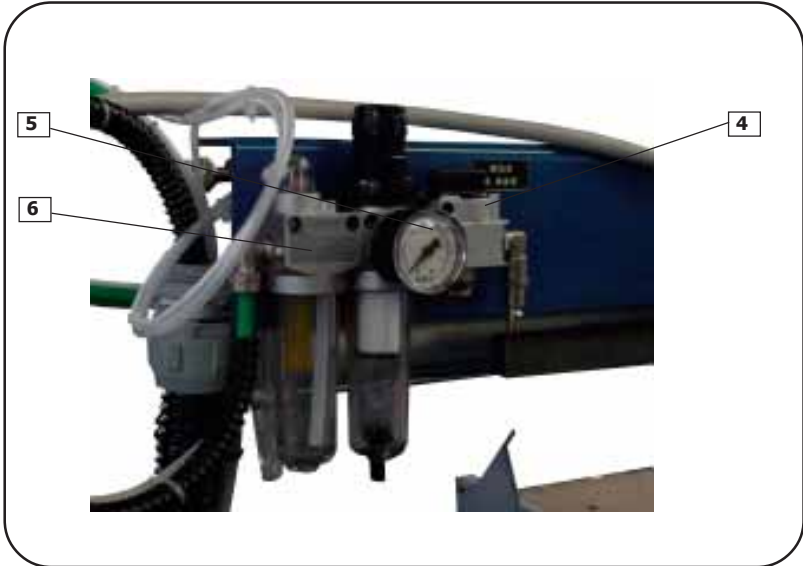

		<i>ITALIANO</i>	<i>ENGLISH</i>
<i>N°</i>	<i>CODE</i>	<i>DESCRIZIONE</i>	<i>DESCRIPTION</i>
1	<i>1701608400</i>	Cilindro freno	Brake cylinder
2	<i>1701407700</i>	Cilindro	Cylinder
3	<i>1800600207</i>	Dosatore di mandata	Delivery regulator
4	<i>1800800103</i>	Scarico rapido	Rapid discharge
5	<i>1803507800</i>	Manometro attacco posteriore	Rear connector pressure gauge
6	<i>1800300203</i>	Gruppo filtro lubrificatore	Lubricating filter unit

**ITALIANO**  
**PARTI**  
**DI RICAMBIO**

**ENGLISH**  
**SPARE**  
**PARTS**



		<b>ITALIANO</b>	<b>ENGLISH</b>
<b>N°</b>	<b>CODE</b>	<b>DESCRIZIONE</b>	<b>DESCRIPTION</b>
1	14010090000	Leva a scatto	Catch lever
2	1801100103	Valvola a leva con cuscinetto	Lever valve with bearing
3	5527	Cremagliera fissa	Fixed rack
4	5529	Cremagliera mobile	Mobile rack
5	5506	Ingranaggio	Gear
6	5879	Feltro	Felt washer
7	5880	Portafeltro	Felt washer holder
8	580120090000	Carrello	Carriage
9	1807907400	Intercettore di blocco	Stop cut-out



*Via Carpi-Ravarino, 146 - 41010 LIMIDI DI SOLIERA (MO) - ITALY*  
*Tel. (059) 897333 - Fax. (059) 565000 - Fax Intl. Line ++39 59 850276*  
*E-Mail: [omga@omga.it](mailto:omga@omga.it)*